

Tow bar rated
at 6,000 pounds

Installation Instructions

852482-02 05/07

ALL SPECIFICATIONS ARE SUBJECT TO CHANGE WITHOUT NOTICE

ROADMASTER, Inc. 5602 N.E. Skyport Way Portland, OR 97218 1-800-669-9690 Fax (503) 288-8900 www.roadmasterinc.com

Owners and installers must read the installation instructions and carefully note the warnings!

Figure 1

Quick-disconnect parts list:
(2) quick-disconnects (parts "A" and "B")
(2) safety plates ("C")
All mounting hardware

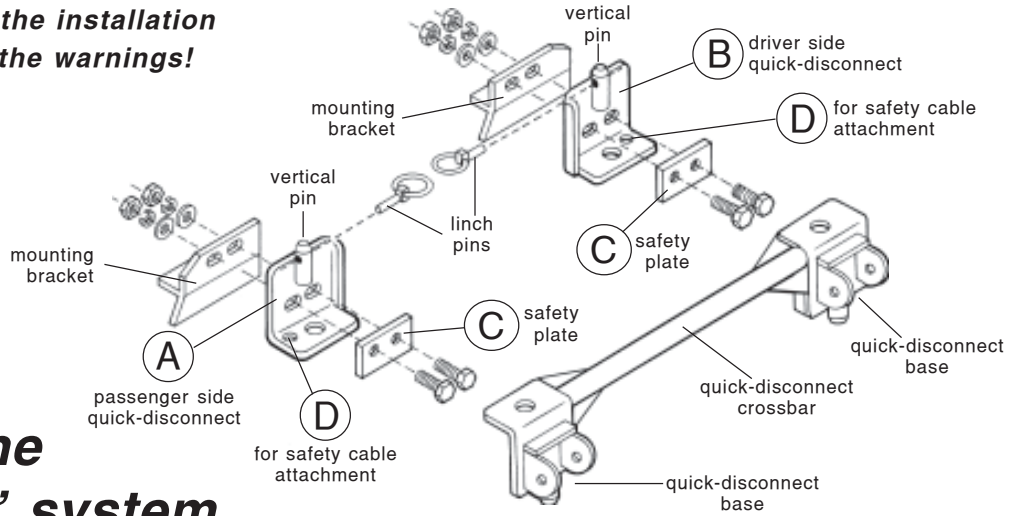

Installing the 'quick-disconnect' system

This tow bar is equipped with a "quick-disconnect" (or, "QD") system. Before connecting the tow bar to the vehicle, first install the components of the QD system to the mounting bracket.

Note: the quick-disconnect system is not used with ROADMASTER 'MS' or 'MX' series mounting brackets. If the towed vehicle has MS or MX brackets, proceed to "Connecting the tow bar," on page three. The quick-disconnect system should be reserved, however, for subsequent vehicles which may not have these brackets.

1. First, attach the quick-disconnects ("QDs," parts "A" and "B" in Figure 1) to the tow bar mounting brackets. Attach the QDs so that the vertical pin on each is pointing up, as shown in Figure 1.

Attach part "A" on the passenger side, and part "B" on the driver side. Use the supplied 1/2" x 1 1/2" bolts, the two safety plates (parts "C"), and the flat washers, lock washers and nuts, as shown in Figure 1.

Note that both QDs have an extra hole – "D" in Figure 1 – for safety cable attachment. Mount parts "A" and "B" so that the "D" holes are to the outside.

Do not tighten any of the bolts – leave them loose for now – they will be tightened later.

WARNING

Use all mounting hardware and both safety plates. If all supplied materials are not used, the quick-disconnects, the quick-disconnect bases, or other components may vibrate loose, which may cause property damage, personal injury or even death.

CAUTION

The quick-disconnects must be centered on the mounting brackets. If they are attached too far to the left or the right, the tow bar will not be centered on the towed vehicle, which will cause excessive tire wear and other consequential, non-warranty damage.

2. Now, attach both quick-disconnect ("QD") bases (and the QD crossbar) by lowering them so that the vertical pins of parts "A" and "B" extend upward through the top holes of the QD bases (Figure 2). At the same time, be certain the lower vertical pins of each QD base slide through the lower holes on parts "A" and "B" (Figure 2).

3. Both linch pins must be inserted through the upper holes in the

Figure 2

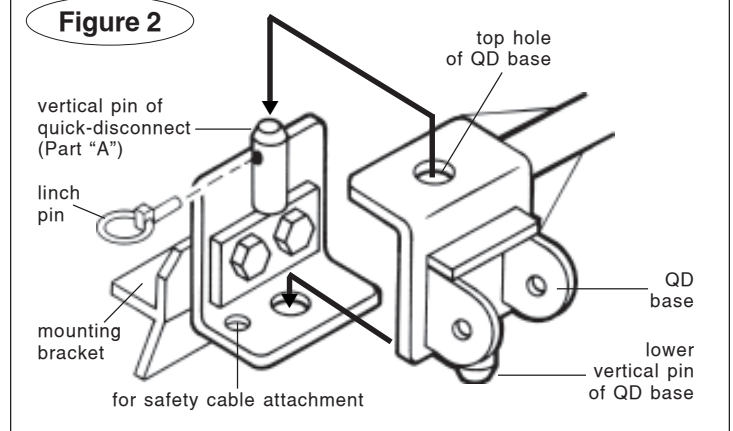

vertical pins in parts "A" and "B," as shown in Figure 2.

Both linch pins must be locked. The rings (Figure 3) are spring-loaded – they must be snapped over the pin, as shown in Figure 3, with the curved side of the linch pin touching the ring and the flat side facing away, in order to keep the QD bases secure.

WARNING

Towing vibrations will force the linch pins out unless they are properly locked in place over the vertical pins on both quick-disconnects. Refer to Figure 3. Failure to install the linch pins properly will result in tow bar malfunction, loss and damage to the vehicle and property, personal injury or even death.

4. Adjust the spacing of QDs "A" and "B" until the QD base slides on and off easily. Now, torque all bolts to 75 ft./lbs.

Figure 3

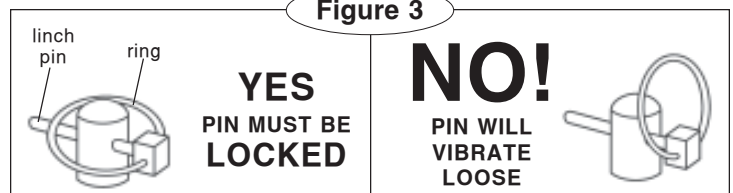

Installer's safety checklist

- **Stress to the owner that the tow bar must be within the 'Safe Zone'** – no more than three inches above level or four inches below level. Towing with an out-of-level tow bar will cause significant wear and tear on the tow bar and mounting brackets, and on the towed vehicle's suspension and frame. (See the section below – "Stay within the 'Safe Zone'" – for further information.)
- **Show the owner how to properly operate the tow bar.** Familiarize yourself with the features of the tow bar. Demonstrate them to the owner, and ask the owner to connect and disconnect the tow bar and other components of the towing system, until the owner is comfortable with its operation.
- **Caution the owner to use a receiver hitch rated higher than the actual weight of the towed vehicle.** The motorhome receiver hitch must have a minimum capacity of no less than the weight of the towed vehicle and all its contents.
(The Falcon All Terrain tow bar is rated at a maximum of 6,000 pounds carrying capacity; therefore ROADMASTER has used 6,000 pounds as a standard for rating the weight capacity of all supplementary towing equipment, as well as the towed vehicle and all its contents, throughout these instructions.)
- **The tow bar must be attached to a bracket which is bolted to the towed vehicle's frame or unibody.** In order to be towed, virtually all vehicles require a tow bar mounting bracket that is connected to the frame, unibody or chassis and extends beyond the bumper.
- **Caution the owner to secure the tow bar with linch pins (or optional padlocks) before towing.** Unless the tow bar is secured to both vehicles with all appropriate pins (or padlocks), the towed vehicle will detach.

- **Advise the owner to use 6,000 pound or higher rated safety cables.**
- **Read the instructions thoroughly before installing the 'quick-disconnect' ('QD') system and its components.** The tow bar will be attached to the QD system. If the QD system is not properly aligned, centered and positioned on the towed vehicle, the tow bar will not be centered on the towed vehicle, which may cause excessive tire wear and other consequential, non-warranty damage.
- **The installer must be sure that the vehicle is suitable or adaptable for towing.** Some vehicles must be equipped with a transmission lube pump, an axle disconnect, driveline disconnect or free-wheeling hubs before they can be towed. Failure to properly equip the vehicle will cause severe damage to the transmission.
Check the manufacturer's instructions for the proper procedure(s) to prepare the vehicle for towing.
- **The installer must NOT use the tow bar as a ground for welding.** Connecting a ground to the 'A-frame' of the tow bar will cause current to flow through the locking spring, which will detemper the spring and destroy the locking mechanism.
- **Under no circumstances should the tow bar be welded to the vehicle,** nor should any of the pre-punched mounting holes be altered. Any welding or altering of the tow bar will void the owner's warranty.

⚠ WARNING

Failure to follow these instructions may cause property damage, personal injury or even death.



Stay within the 'Safe Zone'

Use one of the accessories below to level the receiver hitch to the tow bar.



The shanks on the **Hi-Low Drops** can be turned up or down, for low- or high-ground clearance. They are available in a four-inch (part number 070) and a six-inch model (part number 076).



The shanks on the **Hi-Low Hitches** can also be turned up or down, for low- or high-ground clearance. They are available in four-inch (part number 048-4), six-inch (part number 048-6), eight-inch (part number 048-8) and 10-inch (part number 048-10) models.



The **Dual Hitch Receiver** is primarily designed to double the hitch receivers, for additional storage capacity. However, they will also level the hitch to the tow bar. They are available in a two-inch (part number 077-2) and a four-inch (part number 077-4) model.

Towing with a motorhome-mounted tow bar which has an upward or downward slope puts undue strain on the entire towing system. For that reason, **do not tow if the tow bar is not within the 'Safe Zone' – no more than three inches above level or four inches below level.**

Towing a vehicle with a tow bar that is not within the Safe Zone will result in significant wear and tear on the tow bar and brackets, significant wear and tear on the vehicle's suspension and frame, and the eventual failure of the towing system.

To determine if the tow bar is within the Safe Zone – first, connect the motorhome and towed vehicle on level ground. Next, measure the distance from the center of the motorhome receiver down to the ground. Then, measure the distance from the center of one of the base pins down to the ground.

Compare these two measurements. To be within the Safe Zone, they cannot be more than three inches apart if the base pin is above the motorhome hitch receiver, or four inches apart if the base pin is below the motorhome hitch receiver.

If the tow bar is not within the Safe Zone, you must purchase a hitch accessory to raise or lower the hitch receiver. ROADMASTER has three accessories available – Hi-Low Hitches, Hi-Low Drops, and Dual Hitch Receivers – which will raise or lower the hitch receiver from two to 10 inches, depending on the model.

Towing with the tow bar more than three inches above level or four inches below level will void the ROADMASTER warranty.

⚠ WARNING

Failure to follow these instructions may cause property damage, personal injury or even death.

Connecting and disconnecting

CAUTION

Use caution when handling the tow bar – if your hands, fingers or any part of your body are caught between moving components, they can be pinched, cut or otherwise injured.

Connecting the tow bar

1. Follow the section in these instructions – “Installing the ‘quick-disconnect’ system” (page one) – to attach the tow bar quick-disconnects (“QDs”) and the QD bases.

Note: the quick-disconnect system is not used with ROADMASTER ‘MS’ or ‘MX’ series mounting brackets. Instead, the tow bar is connected directly to the mounting bracket with the base pins and linch pins.

With this exception, the instructions below apply.

2. Drive the vehicle within three or three-and-a-half feet of the motorhome hitch receiver. The vehicle does not have to be perfectly centered to the hitch receiver, just close. Then, put the vehicle in gear (park), set the emergency brake and chock one of the wheels.

3. With the tow bar in the folded position, insert the stinger into the motorhome hitch receiver, and attach the stinger to the hitch receiver with the hitch pin and clip.

CAUTION

Attach the tow bar so that the locking mechanisms and the release latch are pointing up. Components of the tow bar may be damaged if the tow bar is attached with the release latch and/or the locking mechanisms pointing down.

4. Hold both tow bar arms firmly, and rotate them up, so that they are vertical.

WARNING

Never release the tow bar arms when they are in the vertical position. The arms can fall and cause severe personal injury.

5. Push the release latch forward, to bring both arms down to a horizontal position.

Standing to one side, swing both arms away from you. Then, align the holes in the outermost arm with the holes in one of the tabs on the quick-disconnect base.

Attach the tow bar arm to the quick-disconnect base with one of the included base pins. Lock the base pin with a linch pin (or optional padlock).

The linch pin must be locked. The ring is spring-loaded – it must be snapped over the pin, with the curved side of the linch pin touching the ring, in order to keep the base pin secure.

WARNING

Both tow bar arms must be attached to the quick-disconnect bases and locked with a linch pin. Towing vibrations will force the linch pins out unless they are properly locked in place over the base pins on both quick-disconnect bases.

Failure to properly install and lock both base pins will result in the loss of the towed vehicle, which may cause property damage, personal injury or even death.

6. Now, swing the other arm to the opposite side and connect it in the same manner.

7. Attach the safety cables and plug in the electrical wiring cord, according to the supplier’s instructions. Before towing the vehicle, be sure the steering is unlocked, the transmission is in the proper setting, and the emergency brake is released. Remove the wheel chock.

Check the manufacturer’s specifications, the owner’s manual, or talk to the installer for the proper towing procedure(s) or requirement(s) for the vehicle to be towed.

WARNING

Do not tow the vehicle until the tow bar is attached with all pins or padlocks. Unless the tow bar is secured to both vehicles with all appropriate pins or padlocks, the vehicle will detach, which may cause property damage, personal injury or even death.

When you drive away, steer briefly to the left and then to the right, to extend, self-center and lock the tow bar.

Always stop at this time. Check the tow bar to ensure that both arms are locked, before assuming highway speed. Additionally, check the other components of your towing system, to ensure that they are fully engaged.

WARNING

Do not tow a vehicle using tow bar mounting brackets, safety cables, or a hitch receiver rated less than the actual weight of the towed vehicle.

If the brackets, safety cables, hitch receiver or any supplementary towing equipment is not rated at the weight of the towed vehicle and all its contents, it may fail during towing, causing property damage, personal injury or even death.

WARNING

If the motorhome hitch receiver has an extension, do not tow if the tow bar is more than three inches out of level.

Receiver extensions cause the towing system to swing much higher and lower than towing systems without extensions. This enlarged arc of motion creates excessive strain on the tow bar, brackets and frame, which can cause the towing system to fail, causing property damage, personal injury or even death.

Disconnecting the tow bar

1. Disconnecting the tow bar is essentially the reverse of connecting it. First, always try to park on level ground, with the towed vehicle in line with the motorhome. This will eliminate most of the tension between the vehicles, allowing for an easier disconnect.

2. Disconnect the electrical wiring harness, safety cables, and any other towing system accessories.

3. Slide the release tool over one of the tow bar arms to release the Autowlok locking mechanism.

(Usually, one of the locks will require more pressure to release. This is the arm that has the majority of the tension between the two vehicles.)

WARNING

Always put the towed vehicle in gear (park), set the emergency brake and chock one of the wheels after releasing the Autowlok locking mechanisms, and before removing the base pins. Failure to do so may result in a ‘runaway’ vehicle or may crush you between the towed vehicle and the motorhome, causing property damage, personal injury, or even death.

4. Put the towed vehicle in gear (park), set the emergency brake, and chock one of the wheels.

5. Remove the base pins and store the tow bar on the motorhome by reversing the connection procedure (under “Connecting the tow bar”). (ROADMASTER recommends replacing at least one of the linch pins with a padlock – part number 301, 302 or 308 – to prevent accidental release or theft.)

WARNING

Failure to follow these instructions may cause property damage, personal injury or even death.

The Falcon All Terrain owner’s manual...

...contains illustrations to accompany the instructions on this page, as well as important safety information, the limited warranty, and other information to make your towing experience safe and pleasant.

Read the owner’s manual cover to cover before towing a vehicle.



Figure 4

short safety cable
Use quick links for easy attachment and removal of cables.

long safety cable

The built-in cable guides will help prevent the safety cables and 12-volt electrical cord from being damaged.

Some ROADMASTER tow bar mounting brackets with removable arms, such as the ones in Figures 4 and 5, use both a long safety cable and a short safety cable on each side.

Each **long safety cable** runs from the towing vehicle to a **quick link** attaching it to one of the quick-disconnects. This quick link is also an attachment point for one of the **short safety cables**; another quick link attaches the short safety cable to the mounting bracket.

Unscrew the nuts on each quick link to connect the safety cable loops. Finger-tighten the nuts firmly, until the loop is completely closed, to secure the attachment.

Do not substitute carabiners or other devices for the quick links – the quick links are rated at 6,000 pounds carrying capacity; carabiners or other devices are not.

Only ROADMASTER bracket kits with removable arms have these short safety cables. Other bracket kits are bolted directly to the frame of the towed vehicle and do not require short safety cables.

If your ROADMASTER bracket kit contains short safety cables, refer to the installation instructions for complete information.

WARNING

The safety cables must be carefully routed so that they cannot become pinched, frayed, scraped or otherwise damaged, and so they will not drag when going over dips or low spots.

Do not use the cables if they show any signs of wear or damage – immediately discontinue towing and replace the cables.

Failure to follow these instructions will result in cable failure, which may cause property damage, personal injury or even death.

WARNING

If the quick links are not completely tightened, with the loop closed, the safety cables may detach. In the event of a towing system failure, the towed vehicle will detach, which may cause property damage, personal injury or even death.

WARNING

If your towing system requires two sets of safety cables, always use both the long and the short safety cables. Connect them as shown in Figures 4 and 5. Otherwise, in the event of a towing system failure, the towed vehicle will detach, which may cause property damage, personal injury or even death.

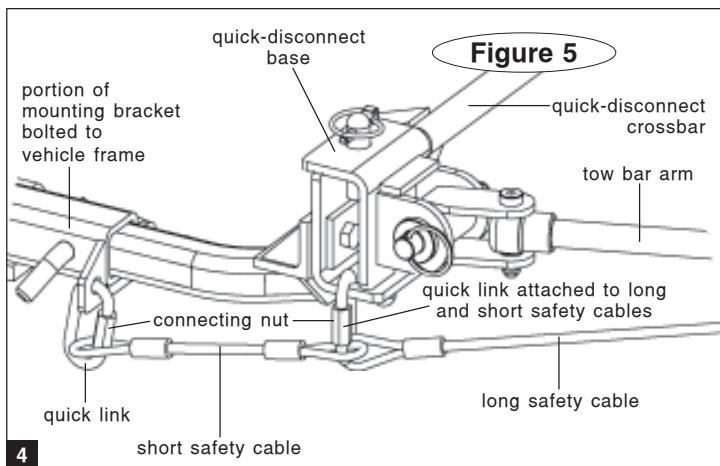

Figure 5

Proper installation of safety cables

Cross the safety cables under the hitch and stinger. This helps prevent the tow bar from hitting the road and “pole vaulting” if the tow bar separates from the hitch receiver.

Connect the **snap hooks** to the loops on the hitch or frame.

How to use safety cables

- The safety cables must connect the towing vehicle to the towed vehicle, frame to frame.
- The safety cables must be rated at 6,000 pounds weight capacity per pair, or higher. This is the maximum weight capacity of the tow bar – the towed vehicle and all its contents cannot exceed 6,000 pounds.
- Pull the safety cables so that all the slack is at the motorhome. **Make sure there is enough slack in the cables at the motorhome to allow for sharp turns** – if there is not enough slack, the towing system will be severely damaged when the motorhome turns a sharp corner.
- The safety cables must be the correct length...
 - Make sure the cables are not too short – if you use a receiver hitch extension or other equipment that extends the distance between the towed vehicle and the motorhome, the standard cables may be too short. If the cables are too short, the towing system will be severely damaged when the motorhome turns a sharp corner. (Twelve-inch safety cable extensions, part number 910648-12, are available from ROADMASTER.)
 - Make sure the cables are not too long – the cables should not hang down to the extent they may catch on obstructions, or drag on the ground. This much slack could cause damage to the towing system, the towed vehicle, or the motorhome. If the cables are too long, wrap the excess cable around the tow bar to take up the slack. **Make sure there is enough slack in the cables at the motorhome to allow for sharp turns.** Damage caused by using safety cables of an incorrect length is not covered under warranty.
- Always cross the cables under the hitch receiver, as shown in Figure 4. In the unlikely event the tow bar separates from the motorhome, crossing the cables will help prevent the tow bar from dragging on the ground, which can cause the tow bar to “pole vault” the towed vehicle.
- Some ROADMASTER tow bar mounting kits with removable arms, such as the ones shown in Figures 4 and 5, use two safety cables on each side. If two sets of safety cables are required, both must be used. This is required by law. Refer to “Proper installation of safety cables,” to the left, for further information.

WARNING

Failure to follow these instructions may cause property damage, personal injury or even death.

The ROADMASTER limited warranty...
...including full warranty text and the product registration card, is enclosed in the Falcon All Terrain literature package.